

## STRAUB-FLEX 1L Ø 48.3 - 168.3 mm

Components / Materials	W1	W2	W4	W5
Casing		AISI 304 / 316 L		AISI 316 L / 316 TI
Bolts		AISI 4135		A4 - 80
Bars		AISI 12 L 14, galvanised		AISI 316 L
Strip insert (option)		AISI 316 L / PVDF		AISI 316 L / PVDF
<b>Sealing sleeve EPDM</b>	Temp.: -20°C up to +100°C Medium: all qualities of water, waste water, air, solids and chemical products			
<b>Sealing sleeve NBR</b>	Temp.: -20°C up to +80°C Medium: water, gas, oil, fuel and other hydrocarbons			
<b>Sealing sleeve FPM / FKM<sup>2</sup></b>	Temp.: -20°C up to +180°C Medium: ozone, oxygen, acids, gas, oil and fuel (only with strip insert)			

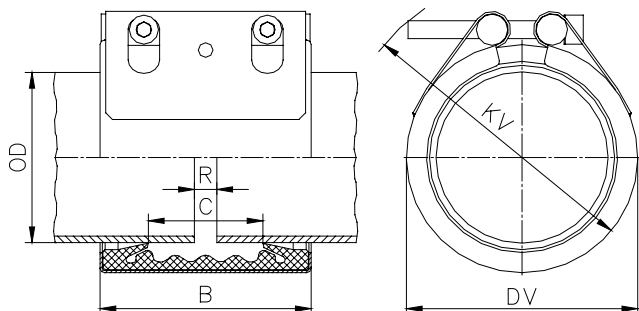

OD [mm]	Clamping range [mm]	PS [bar]	B [mm]	C [mm]	DV [mm]	KV [mm]	R without strip insert [mm]	R with strip insert [mm]	Torque rate [Nm]	Allen head [mm]	Thread M...
<b>48.3<sup>2</sup></b>	<b>47.0 - 49.5</b>	<b>25.0</b>	<b>75</b>	<b>35</b>	<b>70</b>	<b>85</b>	<b>5</b>	<b>15</b>	<b>7.5</b>	<b>6</b>	<b>8</b>
54.0 <sup>2</sup>	52.5 - 55.5	25.0	75	35	76	90	5	15	7.5	6	8
57.0 <sup>2</sup>	55.5 - 58.5	25.0	75	35	79	95	5	15	7.5	6	8
<b>60.3</b>	<b>59.0 - 61.5</b>	<b>25.0</b>	<b>75</b>	<b>35</b>	<b>82</b>	<b>95</b>	<b>5</b>	<b>15</b>	<b>7.5</b>	<b>6</b>	<b>8</b>
<b>73.0</b>	<b>71.5 - 74.5</b>	<b>25.0</b>	<b>94</b>	<b>51</b>	<b>95</b>	<b>117</b>	<b>5</b>	<b>25</b>	<b>7.5</b>	<b>6</b>	<b>8</b>
<b>76.1</b>	<b>74.5 - 77.5</b>	<b>25.0</b>	<b>94</b>	<b>51</b>	<b>98</b>	<b>122</b>	<b>5</b>	<b>25</b>	<b>7.5</b>	<b>6</b>	<b>8</b>
84.0	82.5 - 85.5	24.0	94	51	106	127	5	25	7.5	6	8
<b>88.9</b>	<b>87.5 - 90.5</b>	<b>24.0</b>	<b>94</b>	<b>51</b>	<b>111</b>	<b>132</b>	<b>5</b>	<b>25</b>	<b>7.5</b>	<b>6</b>	<b>8</b>
100.6	99.0 - 102.5	23.0	94	51	123	147	5	25	7.5	6	8
<b>101.6</b>	<b>100.0 - 103.5</b>	<b>23.0</b>	<b>94</b>	<b>51</b>	<b>124</b>	<b>147</b>	<b>5</b>	<b>25</b>	<b>7.5</b>	<b>6</b>	<b>8</b>
104.0	102.5 - 105.5	22.0	94	51	126	147	5	25	7.5	6	8
104.8	103.0 - 106.5	22.0	94	51	127	147	5	25	7.5	6	8
108.0	106.5 - 109.5	22.0	94	51	130	152	5	25	7.5	6	8
<b>114.3</b>	<b>112.5 - 116.0</b>	<b>21.0</b>	<b>94</b>	<b>51</b>	<b>136</b>	<b>157</b>	<b>5</b>	<b>25</b>	<b>7.5</b>	<b>6</b>	<b>8</b>
127.0	125.0 - 129.0	19.0	107	62	149	165	5	35	10	8	10
129.0	127.0 - 131.0	18.0	107	62	151	165	5	35	10	8	10
130.2	128.5 - 132.0	18.0	107	62	152	165	5	35	10	8	10
133.0	131.0 - 135.0	16.0	107	62	155	170	5	35	10	8	10
<b>139.7</b>	<b>138.0 - 141.5</b>	<b>16.0</b>	<b>107</b>	<b>62</b>	<b>162</b>	<b>175</b>	<b>5</b>	<b>35</b>	<b>10</b>	<b>8</b>	<b>10</b>
141.3	139.5 - 143.0	16.0	107	62	163	180	5	35	10	8	10
154.0	152.0 - 156.0	16.0	107	62	176	190	5	35	10	8	10
159.0	157.0 - 161.0	16.0	107	62	181	195	5	35	10	8	10
<b>168.3</b>	<b>166.0 - 170.5</b>	<b>16.0</b>	<b>107</b>	<b>62</b>	<b>190</b>	<b>205</b>	<b>5</b>	<b>35</b>	<b>10</b>	<b>8</b>	<b>10</b>

### Remarks:

- Follow fitting / disassembly instructions
- PS = Working pressure considering the application loads  
Test pressure = PS x 1.5 (for example industry, water supply etc.)  
Burst pressure = approx. PS x 2
- Strip inserts are required for special applications

<sup>2</sup> FPM / FKM only available in STRAUB-OPEN-FLEX version

For IPS sizes in bold see technical manual for actual OD